

# Tray Dryer



**POWDER SYSTEMS LIMITED**



## POWDER SYSTEMS LIMITED

PSL BELIEVES IN WORLD CLASS PEOPLE WORKING TOGETHER TO PROVIDE **WORLD CLASS SOLUTIONS**.

Our experienced engineering teams work closely with our skilled chemists to accelerate process development and create the most suitable and ergonomic solutions. PSL's established supply chain management ensures all components, sourced from across the globe, are of the highest quality and value. This enables market savings to be passed directly onto our customers.

PSL is an international manufacturer of filtration, drying and high containment solutions. We have been supporting pharmaceutical, biopharmaceutical, chemical and laboratory industries since 1989.

To complement PSL's existing range of contained drying solutions, we have developed the CakeStand tray dryer (patent pending).



## OUR GLOBAL OFFICE BASE

PSL continues to increase its number of global offices, agents and distributors to aid the smooth distribution of its equipment to any part of the world.



# TRAY DRYERS FROM PSL

FROM KILOGRAMS TO LARGE SCALE PRODUCTION  
EASY CLEANING  
MODULAR DESIGN



PSL's tray drying technology has been carefully developed with efficiency, ergonomics and safety in mind. PSL tray dryers can operate in down-flow booths, clean rooms or in conjunction with PSL containment isolators. A number of design features have been incorporated into our tray dryer designs for ease of use and both operator and product protection.

PSL tray dryers are designed from laboratory to production scale and can meet sterile process requirements when necessary for drying highly toxic or sensitive products.

cGMP  
EXCELLENT HEAT TRANSFER



## CAKESTAND TRAY DRYER | PATENT PENDING

### ENHANCED ERGONOMICS

- Less opportunity for overreaching or accidental spillage
- Optimum tray size
- Pivot door design
- Front and back access

### DIRECT TRAY HEATING

- Heating uniformity across the heating plates
- Unique heat transfer system

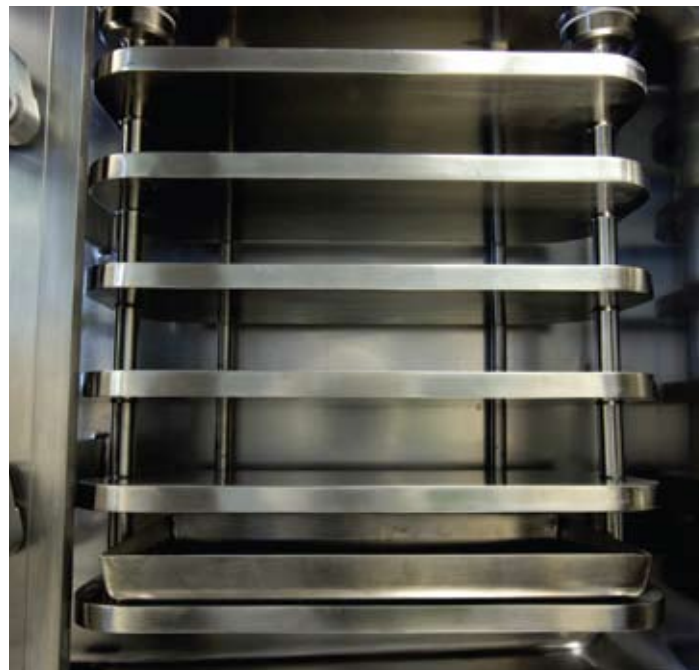

### TOTAL EASE OF CLEANING

- No hidden pockets or non-accessible gaps
- All heating plates hang directly from the roof
- Completely open floor inside the drying cabinet
- Rounded edges and corners

## CAKESTAND MODULE OPTIONS WITHIN PSL GLOVEBOX

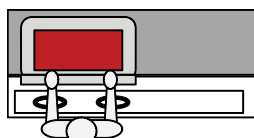

1 Module

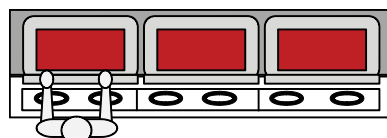

2+ Modules Side by Side

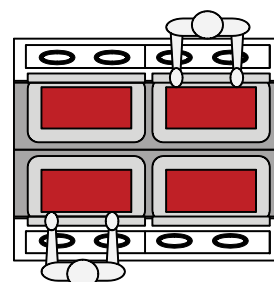

2+ Modules Back to Back

Please note that these are a schematic interpretation of the CakeStand module options within PSL glovebox for illustrative purposes only.

## CAKESTAND TRAY DRYER SPECIFICATIONS

	Free-standing	Within PSL Glovebox
Modules:	N/A	1 Module 2+Modules Side by Side 2+Modules Back to Back
Module High:	6 to 12 trays	Up to 6 trays
Standard Tray Sizes:	500mm x 250mm x 45mm	500mm x 250mm x 45mm
Max Tray Air Volume:	5 Litres	5 Litres
Max Module Air Volume:	240 Litres	30 Litres
Design Temperature Range:	20°C to 150°C	20°C to 150°C
Internal Cavity Pressure:	Full vacuum	Full vacuum
Heated Shelves Pressure:	6 Bar	6 Bar

Instrumentation, control, TCU and vacuum systems can also be provided to meet your requirements.

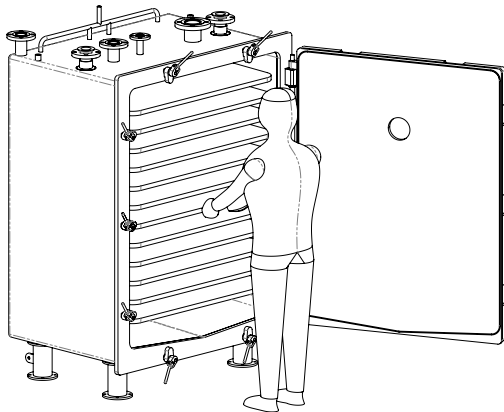

Example of 1 free-standing CakeStand tray dryer

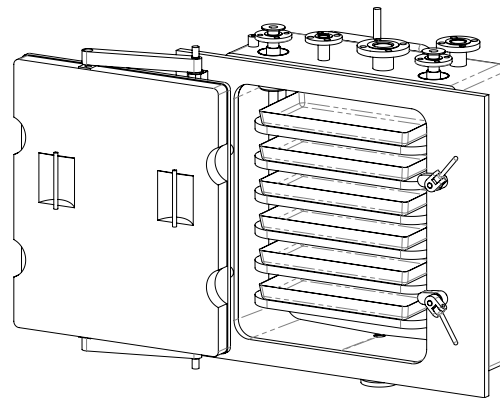

Example of 1 module for CakeStand within PSL glovebox

## PSL TRAY DRYER FEATURES

- Sterile option available
- Containment to nanograms level available
- Laboratory to production scale sizes
- Full vacuum
- Pressure control



## AFTERCARE SERVICE FROM PSL

**PSL Serve** is our dedicated after sales customer care, on-site service and spares team. They are technical specialists, here to aid the smooth installation of new equipment, along with the servicing and repairs of existing PSL equipment and any spare parts required.

The PSL Serve Team can offer full installation, commissioning and training for CakeStand, laboratory and sterile tray dryers. Information on the PSL tray dryer IQ/OQ package is available upon request.

